

ROBUSTNESS EVALUATION AND ROBUST DESIGN OPTIMIZATION OF TURBO MACHINERY

Increased efficiency by sensitivity analysis and optimization with optiSLang® and ANSYS®.

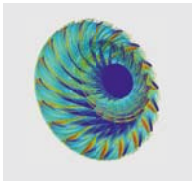

Optimization Task

The economy's ever-increasing need of energy and, at the same time, the rapidly declining resources, have made energy efficiency – and hence Robust Design Optimization (RDO)

– one of the most important challenges for engineering at the moment. During energy transformation, in almost every application the turbo machinery is one of the most important parts of the process chain and, therefore, shows a high potential for optimization. If optimizing processes are carried out with modern automated methods, a large increase in efficiency can be achieved with relatively little effort. A multidisciplinary optimization, which includes both FEA and CFD simulations, is associated with a significant amount of computation. Therefore, it is essential to find efficiently a design fulfilling both the terms of fluid mechanics and the requirements of structural mechanics complying with sufficient safety margins. In order to reduce the required computational effort, prior to the optimization a sensitivity analysis is recommended. This enables the user to identify the most influential input parameter and, by this filtering, a reduction of variables for an efficient optimization is achieved.

Solution Methodology

The use of stochastic sampling methods combined with high-quality meta-models make it possible to detect the parameter space to be analyzed, to determine safely the most important variables and to find the desired optimum with a minimum of solver calls. The software optiSLang developed by the Dynardo GmbH provides all required algorithms in a fully automated workflow.

Running a sensitivity analysis, optiSLang identifies the relevant input parameters, quantifies the quality of forecasting using the **Coefficient of Prognosis (CoP)** and selects the best **Metamodels of Optimal Prognosis (MOP)**. Based on this determination, the number of design variables is reduced decisively as a prerequisite for an efficient optimization and robustness evaluation. The predictable forecasting quality of the parameter identification using optiSLang's Coefficient of Prognosis (CoP) is the key to more efficiency. Thus, a „no run too much“

philosophy can be implemented minimizing solver calls. Based on the determined design improvements using global meta-models, further optimization steps can be conducted. For this purpose, optiSLang provides a variety of optimization algorithms. These include, among others, classical gradient-based algorithms, adaptive response surface methods or nature-inspired optimization methods such as evolutionary strategies or genetic algorithms.

Application example

In the following example, the optimization workflow of a highly stressed centrifugal compressor impeller is described.

Project aim: A geometry optimization of the impeller should be achieved considering its fluid efficiency and mechanical performance in accordance with sufficient safety margins.

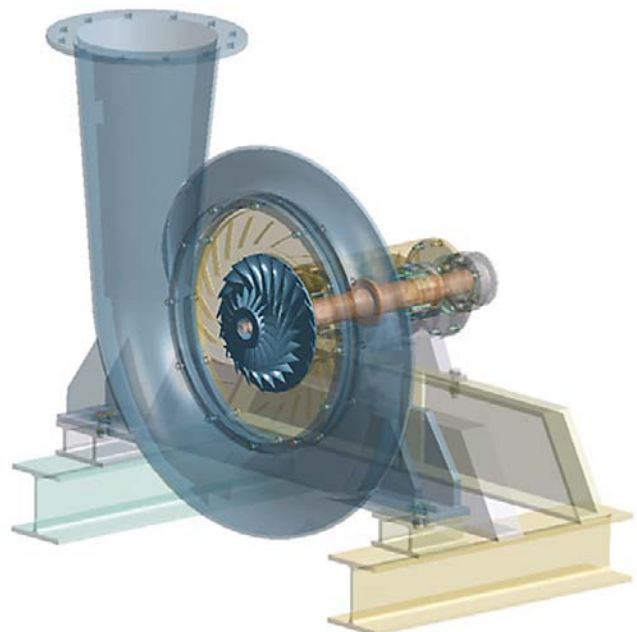

single-stage turbo compressor

Parameterization and sensitivity analysis: Depending on the number of input parameters, using optiSLang's stochastic sampling methods, a "Design of Experiments" (DOE) is created concerning the whole parameter space. The next step is generating a geometry model and the correspond-

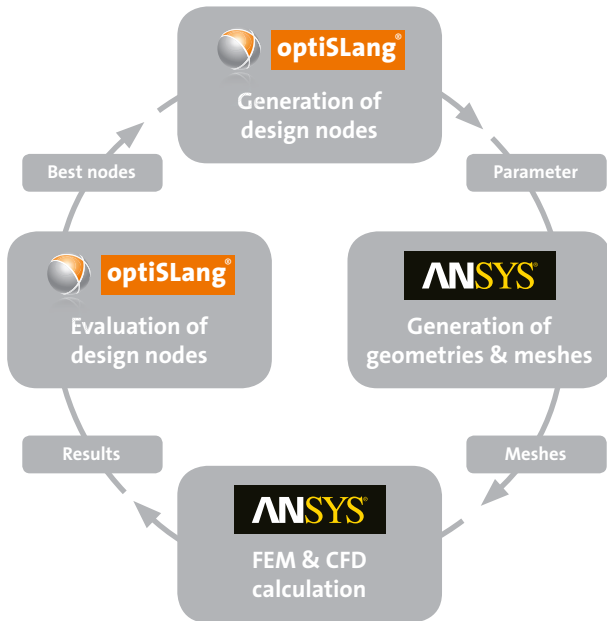

Optimization workflow optiSLang-ANSYS Workbench

ing FEM and CFD meshes out of each design point. In order to ensure a stable and fully parameterized process flow, this step is conducted entirely within ANSYS Workbench. By the use of highly integrated software components, a consistent parameterization and, therefore, a smooth flow of optimization will be ensured. Based on the geometry created with DesignModeler and Blade editor, the network setup of the CFD part is done in Turbogrid and the FEM mesh is generated with the meshing tool within ANSYS Workbench. After the results of all design points are available, an evaluation is carried out in optiSLang. With a sensitivity analysis using the Coefficient of Prognosis (CoP) and the Metamodel of Optimal Prognosis (MOP), the most influential input parameters are identified and can be used for an efficient optimization.

Optimization: A geometry of the compressor impeller generated with a conventional CFD design software is taken as a starting point of the optimization, having already good flow mechanical properties. Due to a design process concerning only the terms of fluid mechanics, however, the stresses within the impeller geometry are far out sufficient safety margins. Therefore, the aim of the optimization is to lower the stresses in the mechanical analysis to a safe level. At the same time, the good fluid properties have to be remained. Before the previously reduced parameter set is used for optimization, optiSLang offers the possibility to utilize the pre-calculated design points from the sensitivity analysis for a first optimization step. This is done by using the „Metamodel of Optimal Prognosis“ (MOP). optiSLang determines, out of a variety of suitable meta-models, and possible subspaces of important parameters, the metamodel, which has the highest prediction accuracy, indicated by the Coefficient of Prognosis (CoP), of the result

value variation. Based on this meta-model, a first global optimization can be run without initiating further solver calls. Only the identified optimum on the meta-model must be validated with an additional numerical calculation. Based on the previously determined design improvements on the global meta-models, further optimization steps can be performed. In this case, an adaptive response surface method is used. In several steps, the parameter space around the previously determined first optimum is adapted. In these parameter spaces, using the meta-models, again design points are calculated and a new optimum is determined.

Customer Benefits

The result of the optimization shows the desired properties. Both the three-dimensional plots and the evaluation of flow and mechanical characteristics clearly demonstrate that the aims are achieved very well. By the use of modern automated optimization methods, a stress reduction is possible while retaining good fluid mechanical properties. Here, the combination of optiSLang's stochastic and optimization algorithms with the parameterization and preprocessing capabilities of ANSYS Workbench proved to be a powerful tool. The tight integration of the software components allows a high degree of automation and, thus, a time- and resource-efficient optimization process. With a minimum of required solver calls, even a complex, high-dimensional optimization problem can be efficiently solved.

